



Installation Manual/Instructions for Use

IFDR USB-C 251 Series USB Chargers

USB 251-M LOG OF REVISIONS

REV NO.	PAGE NO.	DATE	DESCRIPTION	APPROVED
A	ALL	12/07/21	Initial Release	ASH VIJ

TABLE OF CONTENTS

USB 251-M LOG OF REVISIONS.....	2
FOREWORD.....	4
DESCRIPTION.....	5
1.0 GENERAL	5
2.0 MODEL DESCRIPTION	5
3.0 LEADING PARTICULARS	6
4.0 RESTRICTIONS AND LIMITATIONS.....	7
5.0 INSTRUCTIONS FOR CONTINUED MAINTENANCE AND OPERATION	7
6.0 SERVICE FACILITIES	7
7.0 RECOMMENDED INSTALLATION AREAS.....	7
8.0 INSTALLATION INSTRUCTIONS.....	8
9.0 INSTALLATION CHECKS.....	9
10.0 TECHNICAL SPECIFICATIONS	9
11.0 MAINTENANCE INSTRUCTIONS.....	10
12.0 SCHEDULED MAINTENANCE	10
13.0 WEIGHT AND BALANCE / EQUIPMENT LIST	10
14.0 LIMITATIONS	10
15.0 PERFORMANCE	10
16.0 UNIT FAILURE CONDITION:	10
17.0 WARRANTY	12

FOREWORD

This document provides information intended for use by persons who, pursuant to current requirements, are qualified to install this equipment. Because equipment and system installations vary depending on a particular aircraft, this document is intended only as a guideline. If further information is required, contact:

Guardian Avionics, LLC
1840 E Valencia Road
Tucson, AZ 85706
(520) 889-1177
(800) 639-7139
www.guardianavionics.com

We welcome your comments concerning this document. Although every effort has been made to keep it free of errors, some may occur. When reporting a specific problem, please describe it briefly and include the document number, the paragraph/figure/picture/table number, and the page number. Send your comments to the address above.

DESCRIPTION

1.0 GENERAL

Our IFDR USB-C Smart Chargers (251 Series) convert Aircraft voltage (22/32V DC) to $12V \pm 0.25V$. IFDR chargers are smart chargers and are internally rated so they provide the correct Amperage that the iPhone or iPad requires. This could vary from 0.5A to 3.2A. The 251 series model provides dual 3.2Amps outlets. The panel mount units have internally lit LED for ease of use of the charging device during night operations. The unit has built in protection for USB excess current and protects against short circuits.

The units have been tested in accordance with USB.org's "USB Battery Charging 1.2 compliance plan for Dedicated Charging Port (DCP) Compliance standard". The system is in full compliance with the specifications that have been listed.

2.0 MODEL DESCRIPTION

The USB-C chargers come in two different but related versions. These are as listed below

USB 251-101 Dual USB-C Charger (Lighted)

USB 251-301 Dual IFDR Mount USB-C Charger

Differences between chargers

101 – This provides a standard USB-C charger interface on the instrument panel or elsewhere in the aircraft.

301 – This series of USB-C power supplies is built specifically to mount directly on the IFDR Panel Mounts for all variations of the iPad and provides power to the Lightning cable port for these devices. The panel mounts allow users to simply slide in their iPads on the instrument panel and the 301 series of power supplies provide power to the iPad without the user needing to do anything else. With the 251-301 series of chargers, an additional USB-C power connection is made available for use with another device.

In subsequent documentation, the chargers are generically referred to as 251 -***. In case any information specifically refers to a particular model, it will be referred to by its complete name – e.g., USB-C charger 251 – 101.

3.0 LEADING PARTICULARS

PARAMETER	SPECIFICATION
PHYSICAL	
Dimensions (approximate)	2.1” long. X 1.50”W in x 1.50” H
Weight (actual)	2.0 oz.
Unit Cooling	Passive
ENVIRONMENTAL	
Cooling	
Temperature and Altitude	
Temperature	
Non-operating high temperature	+85 °C
Non-operating low temperature	-55 °C
Operating high temperature	+65 °C
Operating low temperature	-20 °C
Humidity	10-90% RH (Non condensing)
POWER REQUIREMENTS	
Power – 22/32 V DC Models	
Current requirement	
Input Voltage	22V to 32V
Minimum input	22V
Maximum input	32V
Max Output USB Voltage	12 Volts ± 0.25V
Amps	0.5A to 3.2A (Smart Charger)
Max Amperage Draw (Dual Simultaneously)	1.43A @ 22V
Max Wire length (20-24 Gauge)	12 ft
Circuit Breaker	5 Amp

4.0 RESTRICTIONS AND LIMITATIONS

This unit is approved under the FAA modifications to improve safety; the relevant approval for all such equipment is explained on our website. This product is manufactured under [21.8\(d\)](#) for equipment designated as to be Minor change per the FAA to type design and whose failure condition is minor. The installation has been determined to be minor per FAA.

Guardian Avionics has determined that the installation of USB-C 251-*** is minor per 14 CFR Part 21.93 as it has no appreciable effect on the weight, balance, structural strength, reliability, operation characteristics or other characteristics affecting the airworthiness of the aircraft it is installed in.

Installation of the USB 251-*** Series is supplemental only; it is not intended as a replacement for or modification to an existing, approved or required system. Installation in a commuter or transport category airplane is prohibited, unless approved by the FAA or local FISDO.

The 251-*** system may not be used as a substitution for the certificated aircraft systems. No operational credit may be taken for installation of the 251-*** system.

5.0 INSTRUCTIONS FOR CONTINUED MAINTENANCE AND OPERATION

USB-C 251-*** are “on condition parts”. No calibration or maintenance is required. If the unit fails to operate as intended, please contact Guardian Avionics.

6.0 SERVICE FACILITIES

The operator can service all components of the installation at an FAA certified Repair Station or by A&P mechanic. The USB charger itself requires no servicing and in the event of un-serviceability, it must only be serviced by Guardian Avionics. Not doing so may void your Warranty. Please see the Warranty section for more details.

7.0 RECOMMENDED INSTALLATION AREAS

USB-C 251-*** can be installed in the aircraft cabin area. Use Guardian Avionics drawing “USB-C 251 Rev. A or later as a reference.

8.0 INSTALLATION INSTRUCTIONS

The latest installation drawings will be available at this link to the Company website. These can be referred to in case of a doubt.

The following documents the installation criteria for the USB-C 251 -*** series of USB chargers

- (a) Choose a location in the instrument panel for the installation of the Unit with space available. Account for the presence of charging cables and ensure that there is adequate space to store the device(s) being charged and ensure that the USB cables and the devices being charged will not interfere with cockpit instrumentation or flying controls.
- (b) Select an area that is not excessively dusty or prone to dirt
- (c) Install the USB circuit breaker (5 AMP) on the non-essential power buss. This will ensure that in the event of a generator failure, USB charging will cut off to minimize load on the aircraft battery.
- (d) Connect the power line to the +22V to +32V DC power output as applicable
- (e) Connect the ground power line to a suitable aircraft structure ground near the circuit breaker panel. The wiring diagram is shown below –

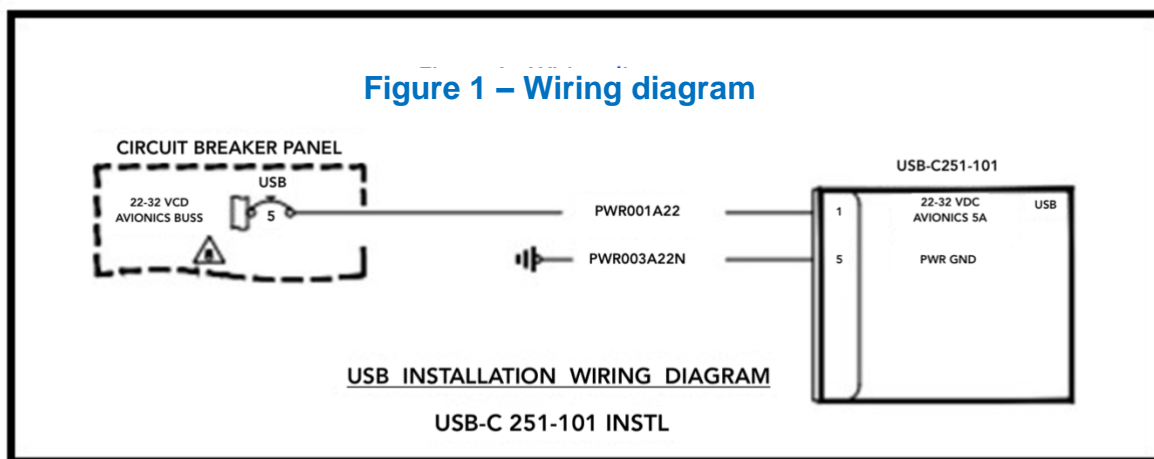

- (f) If a jumper wire is required to connect the USB charger to the CB, use 20 Gauge MIL-W-22759/16 or equivalent wire. Wiring is to be performed in accordance with AC 43.13-1B, 2B, acceptable methods, techniques, and practices.
- (g) Create a mounting hole in the selected location as indicated in Fig 2 and mount the device.

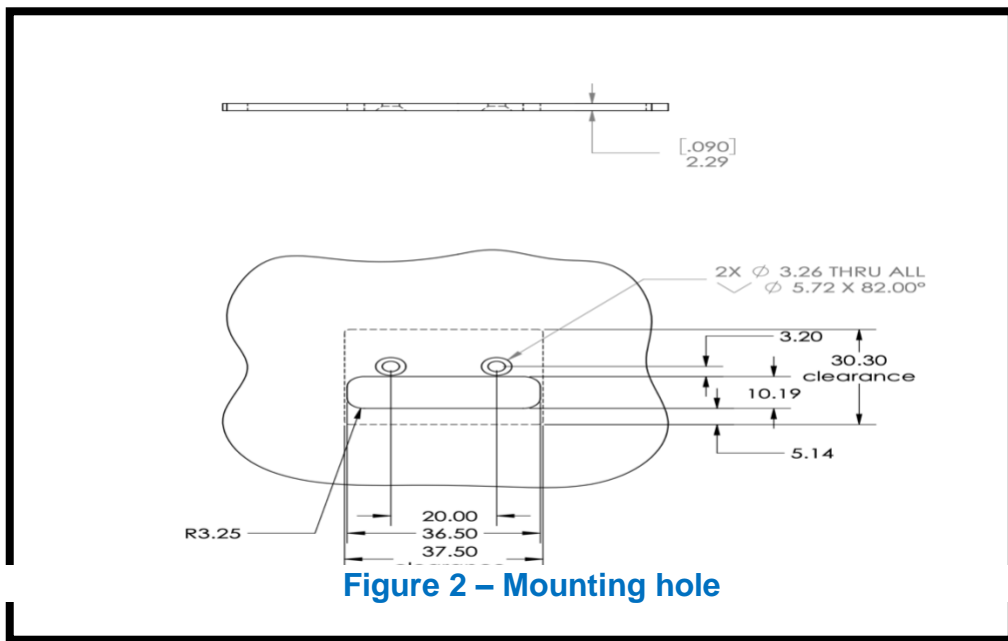

9.0 INSTALLATION CHECKS

- (a) With the USB charger disconnected from the aircraft harness, carry out a continuity check of the added wiring.
- (b) Connect the USB charger connector to the aircraft harness. Turn aircraft Battery Switch ON. Close USB circuit breaker. Check the USB charger for correct operation. Verify the charger can be shut off with the USB circuit breaker

10.0 TECHNICAL SPECIFICATIONS

- Power supply: 22 - 32 V DC
- Power consumption: less than 5 Amps
- Max Current drawn: up to 1.43 amps for 22V dual USB
- Fuse: Use GMI type, fast acting fuse 5A 250V
- Temperature range: -20C to +65C

- Humidity range: 10-90% RH (Non condensing)
- Weight of the unit is approximately 2.0 oz. (Power supply only)

11.0 MAINTENANCE INSTRUCTIONS

The USB Chargers do not require periodic scheduled servicing or periodic scheduled preventive maintenance.

Field repair or service is allowable on all of the installed system components except for the USB Charger itself. The USB Charger must be returned to Guardian Avionics LLC for all services.

The aircraft wiring harness, circuit breaker shall be included maintenance instructions for general visual inspections for system integrity, installation security, corrosion and chaffing.

12.0 SCHEDULED MAINTENANCE

On Condition, No Scheduled maintenance is required.

13.0 WEIGHT AND BALANCE / EQUIPMENT LIST

The weight of the USB-C 251-*** chargers is only 2.0 Oz. There is negligible impact on aircraft balance. Reference the aircraft weight and balance manual for moment arm if change is required.

14.0 LIMITATIONS

The USB-C charger is not designed to replace any existing instrument or indicator required by the type design or operating limits.

15.0 PERFORMANCE

No Change

16.0 UNIT FAILURE CONDITION:

No warning is available in case the unit fails to charge. The USB device that is being

charged will indicate non availability of power supply.

In case the unit does not charge a USB device connected to it, try an alternate USB charging cable. If this does not restore charging, try to clear the failure condition by resetting the USB Circuit breaker. Should the failure condition continue, remove the power by pulling the circuit breaker and get the failure investigated on landing.

17.0 WARRANTY

WARRANTY COVERAGE: CO GUARDIAN LLC. WARRANTS TO THE ORIGINAL CONSUMER PURCHASER, THAT THIS DETECTOR WILL BE FREE OF DEFECTS IN MATERIAL AND WORKMANSHIP FOR A PERIOD OF ONE (1) YEAR FROM DATE OF PURCHASE. THE MANUFACTURER'S LIABILITY HEREUNDER IS LIMITED TO REPLACEMENT OF THE PRODUCT, REPAIR OF THE PRODUCT OR REPLACEMENT OF THE PRODUCT WITH A REPAIRED PRODUCT AT THE DISCRETION OF THE MANUFACTURER. THIS WARRANTY IS VOID IF THE PRODUCT HAS BEEN DAMAGED BY ACCIDENT, UNREASONABLE USE, NEGLIGENCE, TAMPERING OR OTHER CAUSES NOT ARISING FROM DEFECTS IN MATERIAL OR WORKMANSHIP. THIS WARRANTY EXTENDS TO THE ORIGINAL CONSUMER PURCHASER OF THE PRODUCT ONLY.

Warranty Disclaimers: Any implied warranties arising out of this sale, including but not limited to the implied warranties of description, merchantability and fitness for a particular purpose, are limited in duration to the above warranty period. In no event shall the Manufacturer be liable for loss of use of this product or for any indirect, special, incidental or consequential damages, or costs, or expenses incurred by the consumer or any other user of this product, whether due to a breach of contract, negligence, strict liability in tort or otherwise. The manufacturer shall have no liability for any personal injury, property damage or any special, incidental, contingent or consequential damage of any kind resulting from gas leakage, fire or explosion.

Some states do not allow limitations on how long an implied warranty lasts, so the above limitation may not apply to you.

Some states do not allow the exclusion or limitation of consequential or incidental damages, so the above limitations or exclusions may not apply to you.

Legal Remedies: This warranty gives you specific legal rights and you may also have other rights that vary from state to state.

Warranty Performance: During the above warranty period, your product will be replaced with a comparable product if the defective product is returned, postage prepaid, to Guardian Avionics LLC, Customer Service Department, 1951 East Airport Drive, Tucson, AZ 85756, together with proof of purchase date. Please include a note describing the problem when you return the unit. The replacement product will be in warranty for the remainder of the original warranty period or for six months whichever is longer. Other than the cost of postage, no charge will be made for replacement of the defective product.

Important: Do not attempt to open unit. If unit is opened, warranty will be void.

Appropriate insurance coverage is your responsibility. Consult your insurance agent.

NOTE

The warranty will be void if the unit is opened or tampered with.